

Shield - Overall Dimensions of Alarm Valve with Trim

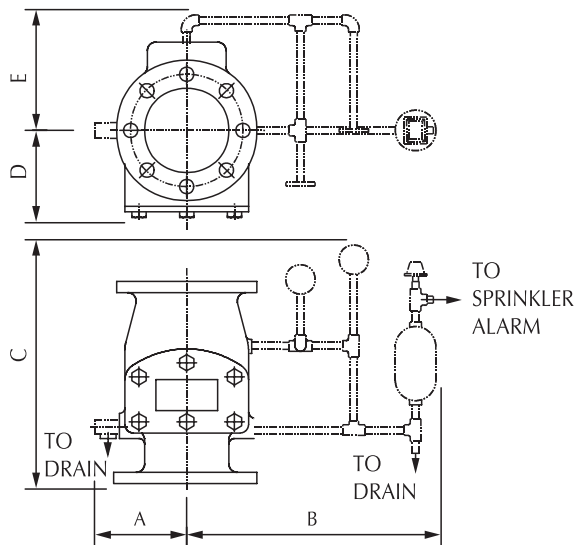

INSTALLATION MEASUREMENT IN MM.
(Approximate)

SIZE	200NB	150NB	100NB	80NB
A	420	400	380	350
B	620	600	550	550
C	790	750	710	710
D	240	230	230	230
E	310	290	290	290

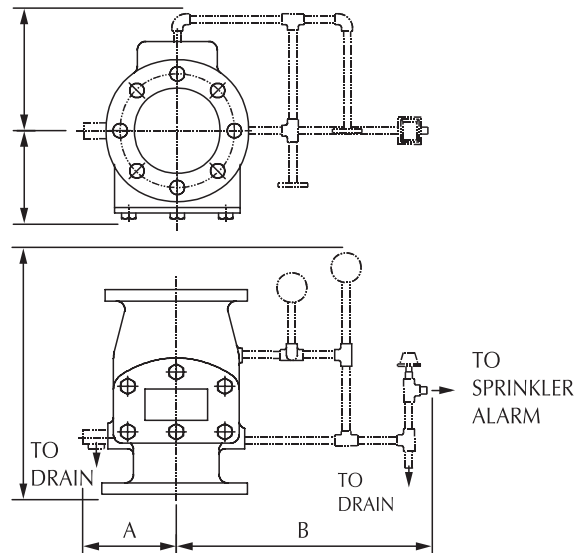

INSTALLATION MEASUREMENT IN MM.
(Approximate)

SIZE	200NB	150NB	100NB	80NB
A	420	400	380	350
B	550	530	490	490
C	790	750	710	710
D	240	230	230	230
E	310	290	290	290

The equipment presented in this bulletin is to be installed in accordance with the latest publication standards of NFPA, TAC or other similar organisations and also with the provision of government codes or ordinances wherever applicable.

The information provided by us are to the best of our knowledge and belief, and are general guidelines only Site handling and installation control is beyond our reach. Hence we give no guarantee for result and take no liability for damages, loss or penalties whatsoever, resulting from our suggestion, information, recommendation or damages due to our product.

Product development is a continuous programme and hence the right to modify any specification without prior notice is reserved with the company.



Shield/2005 - Shield reserves the right to change the contents without notice.